

NUMERICAL SIMULATION OF COMPLEX LARGE DEFORMATION PROCESSES

B.M. Chaparro¹, J.M. Antunes¹, L.F. Menezes², S. Thuiller³, P.Y. Manach³

¹*Instituto Politécnico de Castelo Branco, Escola Superior de Tecnologia, Avenida do Empresário, P-6000 Castelo Branco – Portugal*

²*Universidade de Coimbra, CEMUC, Departamento de Engenharia Mecânica – Universidade de Coimbra, Pinhal de Marrocos, P-3030 Coimbra – Portugal*

³*Laboratoire Génie Mécanique et Matériaux, Université de Bretagne Sud, Rue de Saint Maudé, 56325 Lorient – France*

SUMMARY: In recent years, the development of new material models has allowed to predict the mechanical behaviour of metals in complex strain paths. In this paper, a comparative analysis of numerical results, obtained with different constitutive models, is presented. Those models were implemented in the finite element code DD3IMP, devoted to the numerical simulation of the deep-drawing process. We focus the ability of the GID application to visualize and compare the results of different mechanical models, particularly the evolution of the stress and strain fields, contact forces, displacements, etc., calculated during the numerical simulation of the deformation process.

KEYWORDS: Large Plastic Deformation, Numerical Simulation, Deep-drawing.

INTRODUCTION

The accuracy of the numerical simulation results depends on various factors being one of them the constitutive models adopted. This is particularly relevant in sequential deformation paths. Nowadays, the industrial numerical simulations in metal forming use simple phenomenological models. In metal forming, the strain paths imposed are usually complex and, in order to describe the material behaviour with increasing accuracy, one needs to use new complex mechanical models based on microstructural evolution during plastic deformation. In this work, we compare the simulation results obtained with the recently proposed Teodosiu & Hu physical model [1] with others widely used phenomenological models. The classical Numisheet'93 square cup drawing is simulated.

THE FEM CODE DD3IMP

The DD3IMP finite element code (Deep Drawing 3 Dimensional Implicit) is devoted to the simulation of the deep drawing processes [2]. The used formulation considers large plastic deformations and rotations. This code uses the Hill's 1948 criteria to describe the plastic anisotropic behaviour. The elastic behaviour is considered as isotropic. The contact issue is solved using the classic Coulomb model. In the mechanical formulation an augmented Lagrange multiplier is applied to associate the equilibrium equations with the contact problem. This leads us to a mixed non-linear problem where the final unknowns are the nodal

displacements and the contact forces. A Newton-Rapshon scheme is used to solve this problem in a single iterative loop algorithm. In this code four isotropic hardening constitutive models were implemented to describe the work-hardening behaviour: Isotropic hardening, described by the Swift law; isotropic plus kinematic hardening, where the Swift law is used to describe the isotropic hardening whereas a saturation Voce type equation describes the kinematic hardening; isotropic and kinematic hardening using in both situations a saturation Voce type equation and, finally, a distortional hardening described by the microstructural based Teodosiu & Hu model.

TOOLS AND SHEET DESCRIPTION

To increase versatility and usefulness, the code use Bezier surfaces to describe the stamping tools. The present problem is the classical Numisheet'93 cup deep-drawing. The sheet is modeled with three-linear eight nodes isoparametric hexahedron associated to a selective reduced integration technique. Taking into account the geometry, it is only simulated a fourth part of the tools and the sheet (fig. 1 and 2).

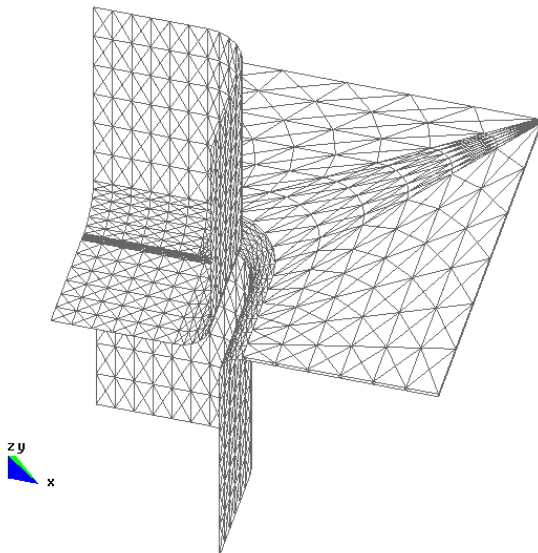

Figure 1: Die, blank-holder and punch geometry's.

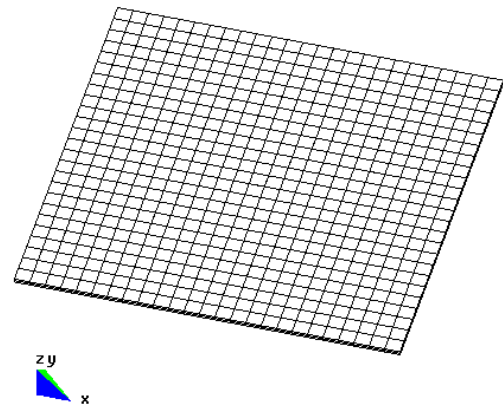

Figure 2: Sheet discretization.

The deep-drawing cup is discretized with 1250 elements: 25x25 elements in the sheet plane and 2 elements in thickness. Sixth order Bezier surfaces were used to simulate the geometries of the die, punch and blank-holder. The boundary conditions were: the die is locked, a constant force is applied (4900 N) in the blank-holder tool and the punch stroke is 40 mm. In order to simulate only a quarter of the total problem symmetry displacement restrictions are imposed to the borders of the sheet.

NUMERICAL SIMULATIONS

In order to evaluate the work hardening process, the Teodosiu & Hu model is compared with three classic models. The first one only considers isotropic hardening, fitted by the Swift law; the second one also considers the isotropic work hardening with the Swift law but with kinematic work hardening with a saturation value, described by a Voce type law; the last one considers a saturation value for both work hardening components. The material properties correspond to a mild steel and were taken from the literature [3]. The Coulombs friction coefficient used in the simulations was 0.144.

RESULTS

To compare and visualize the evolution of the main variables of the deformation process the software GID was used. Figures 3 to 10 shows the distribution over the deformed sheet of some of them.

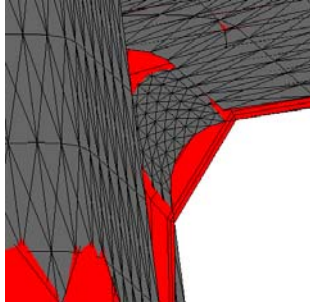

Figure 3: Detail of the tools-sheet contact.

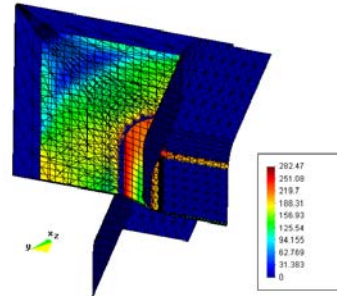

Figure 4: Global view at 5 mm punch displacement obtained with Swift model.

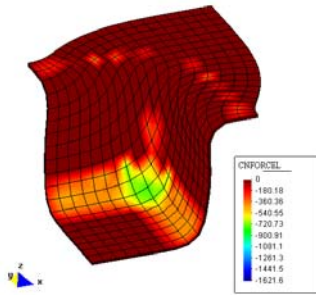

Figure 5: Normal contact forces distribution at 40 mm punch displacement obtained with Teodosiu & Hu model.

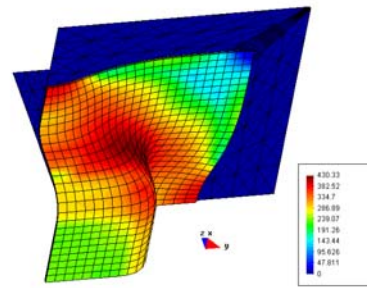

Figure 6: View of the deformation process without the die tool at 40 mm punch displacement for Teodosiu & Hu model.

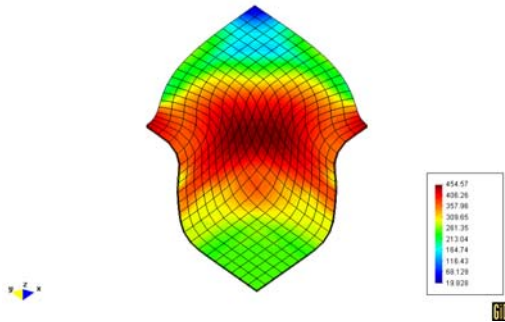

Figure 7: Equivalent stress distribution for the simple Swift model at 40 mm punch displacement.

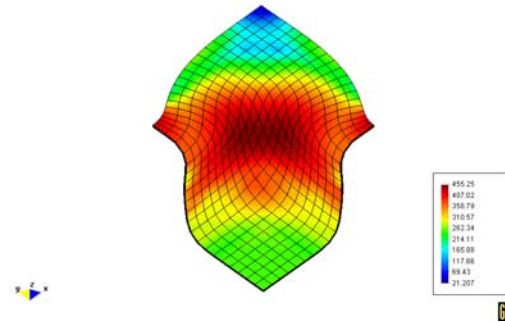

Figure 8: Equivalent stress distribution for the Swift law with back stress Kinematic Voce type law at 40 mm punch displacement.

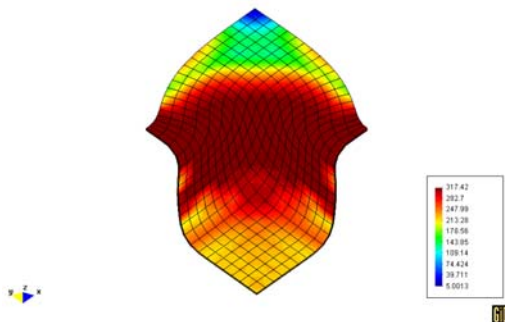

Figure 9: Equivalent stress distribution for the Voce-Voce type model at 40 mm punch displacement.

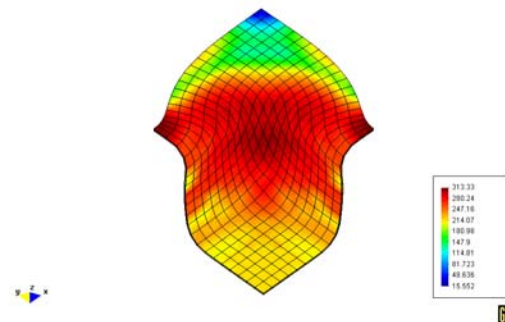

Figure 10: Equivalent stress distribution for the Teodosiu & Hu model at 40 mm punch displacement.

It is possible to observe in figure 3 some contact details that can help us to define the level of discretization needed for our problem. In figures 4 to 6, it is shown, respectively, an initial deformation state, the final normal contact forces distribution and, finally, a detail showing the equivalent stress state distribution on the sample sheet at the final of the deformation process. In figures 7 to 10, it is possible to compare the stress state distribution obtained at 40 mm punch stroke for the four constitutive models used.

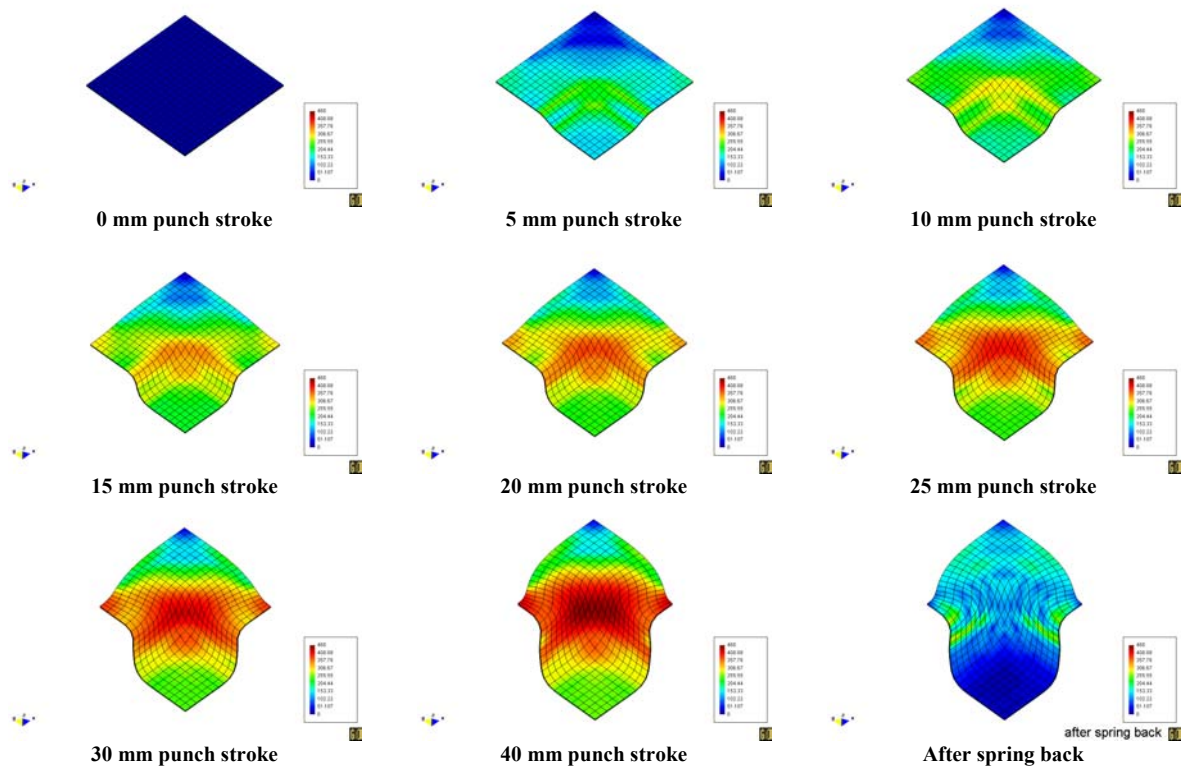

Figure 11: Equivalent stress state evolution in the steel metal sheet

In figure 11 it is presented the equivalent stress evolution during the deformation for the isotropic Swift hardening without kinematic hardening.

CONCLUSION

It is easy to observe global or detailed information about large deformation parameters evolution using GID: this includes the typical state parameters in nodes or on the integration points. In this paper, the results of the intuitive interaction between the pre and post processor GID with the DD3IMP solver developed at the CEMUC (Centro de Engenharia Mecânica da Universidade de Coimbra) are shown. The GID software was used to create the initial sheet geometry and to do all the post-process tasks. To conclude is possible to assure that this program brings us a real answer to many solver developers' problems.

REFERENCES

1. Teodosiu, C., Hu, Z., Evolution of the intragranular microstructure at moderate and large strains: Modeling and computational significance, Simulation of Materials Processing: Theory, Methods and Applications, 173, 1997.
2. L. F. Menezes, C. Teodosiu, A. Makinouchi in: FE Simulation of 3D Sheet Metal Forming Processes in Automotive Industry, Tangungsbericht Der VDI-Gesellschaft Fahrzeugtechnik, Düsseldorf, 894, 1991.
3. Reis, A., Modelação Numérica por Elementos Finitos de Processos de Conformação Plástica, mSc thesis, Oporto University, 2001.